

RCDC2 Radio Controlled Device Controller- 2 channel

- Power input can be anywhere from +9VDC to +24VDC and is applied as shown above.
- Compact- only 3.3” square
- The 2 relays are SPDT (single pole, double throw: one common contact, one normally open contact and one normally closed contact) capable of handling up to 10 amps.
- Normally open, normally closed, and common connections of each relay are brought out on the terminal blocks as shown above.
- The “Channel Center” LEDs provide built-in diagnostics. They light when the RC transmitter joystick is at center for that channel and the trim is set properly for a 1.5 ms “neutral” pulse.
- The “Relay Operated” LEDs also provide built-in diagnostics. They light when the relays have been energized.
- +5V is available from the card to power an RC receiver eliminating the receiver battery.
- May be wired, and mode switches set, to control the direction of a motor (not speed) as well as on/off in either the latched or momentary mode.
- May be wired, and mode switches set, to control 2 separate and independent devices in either the latched or momentary mode.

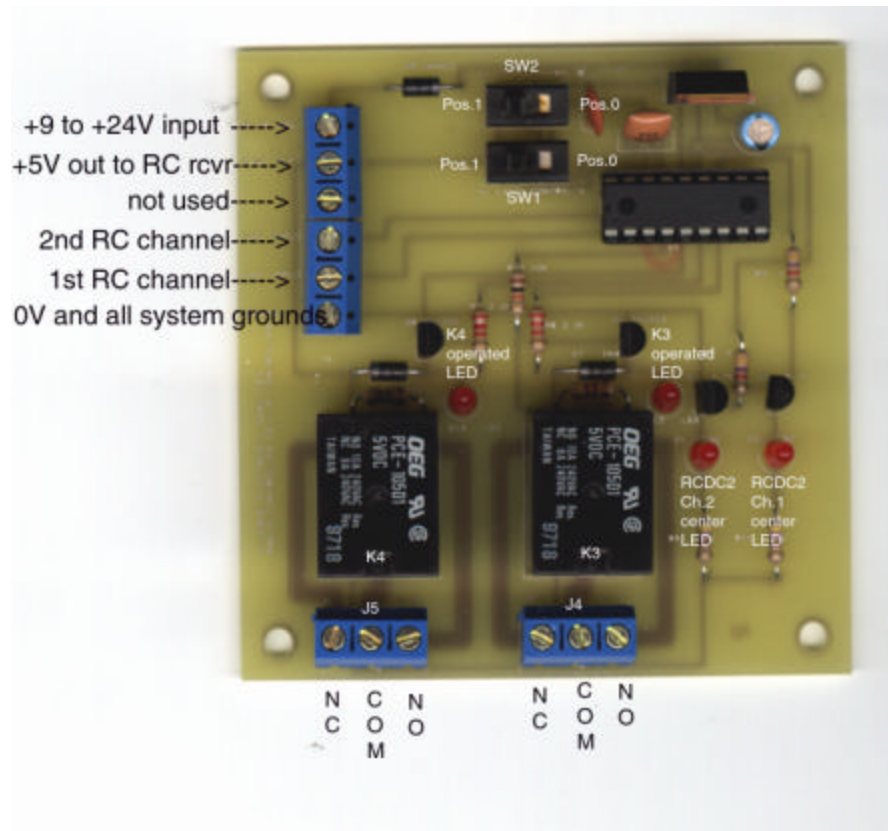

RCDC-2 Radio Controlled Device Controller- 1 or 2 Channel

The RCDC-2 is a handy little circuit board (3.3 X 3.3") that can be used to turn any device on or off whether it is AC or DC operated, via a standard radio controlled transmitter and receiver. It was specifically designed to be used to control a one or two weapons on a robot, or the direction of a motor, but can be used to turn on or off any device, 10 amps or less by radio control.

It has two switch selectable modes, momentary or latched. In the momentary position, the relay(s) are activated as long as the RC input pulse is longer than ~1.75 ms and, depending on the mode selected, either released when the joystick is returned to center or latched on or off. Depending upon the mode selected, one of the relays can be made to activate as the other is turned off. This is useful for when the relays are wired in a reversing configuration to a motor. This can control the direction of a weapons motor or even a drive motor (without speed control). Relay activation occurs when the joystick is pushed about three quarters of the way forward or to the right (depending upon which receiver channel is being used for control). The "three quarters" parameter was chosen to insure that the controlled device does not get activated accidentally by bumping the joystick. In the latched mode, moving the joystick to one side of center turns on the relay. When the joystick returns to center, the relay stays on. Putting the joystick to the other side of center, releases the relay.

The relays are compact units capable of handling loads up to 10 amps. The relay outputs are accessible via 3 position terminal blocks located next to the relays. There are 3 contact connections for each relay. These are: a common contact which makes or breaks contact with the other two contacts, a normally open contact which does not connect to the common contact until the relay is energized, and a normally closed contact which is connected to the common contact in the de-energized position and which opens up in the energized position.

The RCDC2 has 4 LEDs. Two of the LEDs light when the RCDC2 is seeing a 1.5ms (plus a small dead band) RC pulse on it's channel input. This lets you know that the proper signal for control is present and that that signal is at or near the 1.5 ms "standard". The other LEDs light when the relay has been activated. Both serve as a visual diagnostic on the operative state of the RCDC2.

Power and RC signal connections are made via a 6 position terminal block located in the top left corner of the PCB as shown in the above picture. Only 5 of the 6 positions are used in this model. The top most pin (#1) is a power-input pin. Any voltage from 9 to 24 volts may be applied here. Pin number 2 can be used in either of 2 ways. When 9 to 24 volts is applied to pin #1, it can be used as a 5 volt output point to power your RC receiver so that a separate battery is not necessary. Or, it can be used as a 5 to 6 volt input to power the RCDC2 from the RC Battery. If used in the latter mode, pin 1 **MUST NOT BE CONNECTED**. Pin 3 is not used on this model. Pin #4 is where the output of your chosen channel on your RC receiver is connected. It is designated as the Ch2 input on the RCDC2. Pin #5 is where another output of your chosen channel on your RC receiver is connected. It is designated as the Ch1 input on the RCDC2. Both of these pins go directly to the microprocessor and is monitored for RC pulses to act upon. Pin #6 is your circuit ground (a.k.a. 0V). **IT MUST BE CONNECTED TO ALL OTHER SYSTEM GROUNDS.**

The two slide switches are used to select the mode of operation (momentary or latched) and whether the relays will operate together or separately. Sliding the switches towards the edge of the board is position 1. Sliding the switches toward the center of the board is position 0.

SW1 (the switch nearest the micro) selects whether the relays will operate as individual units or operate together.

SW2 (the switch shown near the top edge of the board) chooses whether the board operates in the momentary mode or the latched mode. Latched mode is selected by choosing position 0 while choosing position 1 enters momentary mode.

S1 & S2 Mode Switch Configuration and Resulting Relay Action

<u>Switch Position</u>		<u>Relay Operation</u>
<u>S1</u>	<u>S2</u>	
1	1	<p>Non-latching RCDC2 Ch1 operates K3 RCDC2 Ch2 operates K4 >1.7 ms is “ON”, anything else is “OFF” 2 RC channels used</p>
0	1	<ul style="list-style-type: none"> * Non-latching * 1 RC channel used (RCDC2 Ch1) * >1.7ms operates K4 * <1.3ms operates K3 * joystick center is off for both relays * Relay outputs can be wired for reversing motors or to control 2 different devices
1	0	<ul style="list-style-type: none"> * Latching * 2 RC channels used * On RCDC2 Ch1: >1.7ms turns on K3, <1.3ms turns off K3 * ON RCDC2 Ch2: >1.7ms turns on K4, <1.3ms turns off K4
0	0	<ul style="list-style-type: none"> * Latching * 2 RC channels used * >1.7ms on RCDC2 Ch1 turns K3 ON and simultaneously turns K4 OFF * <1.3ms on RCDC2 Ch1 turns K3 OFF and simultaneously turns K4 ON * Both relays cannot be turned on at the same time * An RC pulse that is not 1.5ms (+/- a small deadband) on RCDC2 Ch2 turns both relays off. The relays can be wired to provide a latched motor reversing configuration.

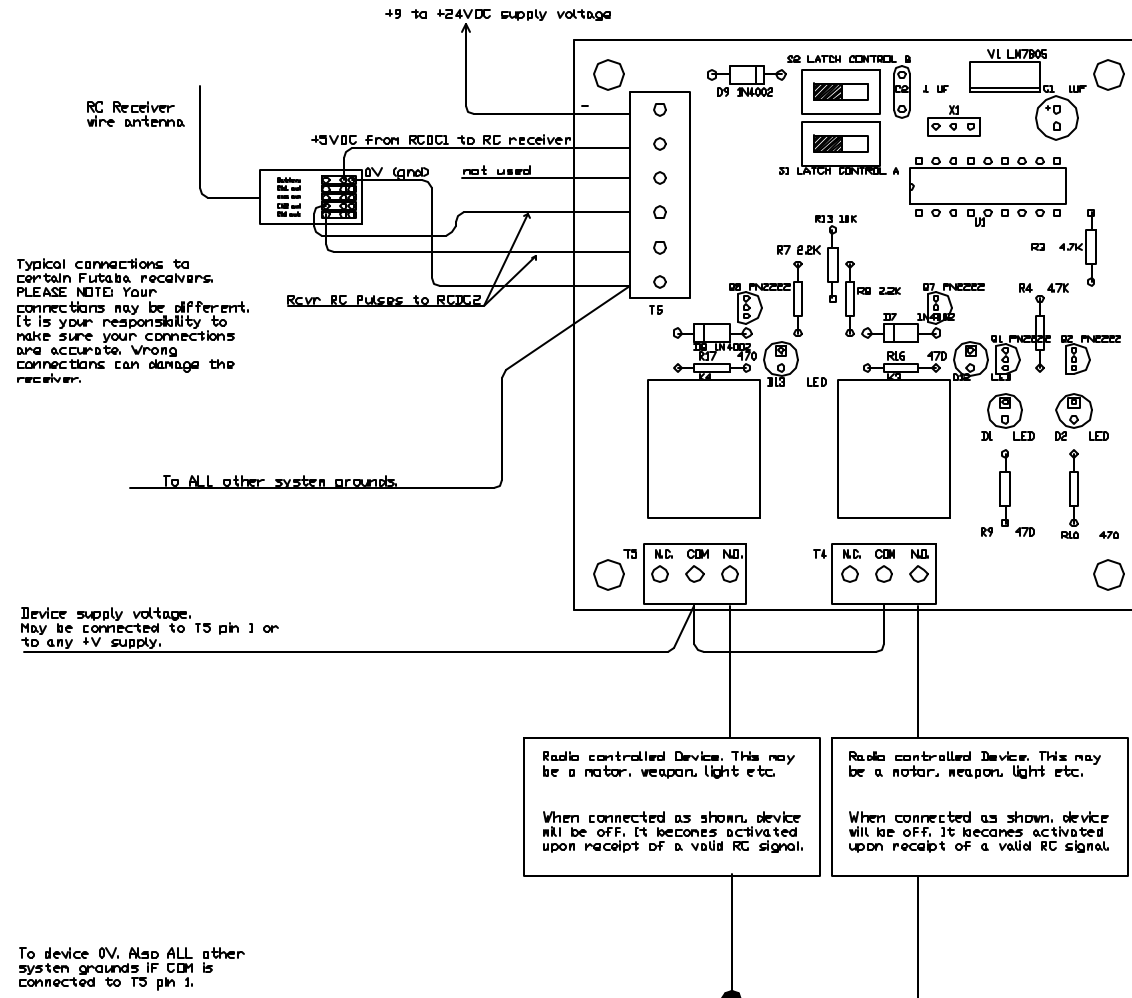

RCDC2 Connections - 2 Devices

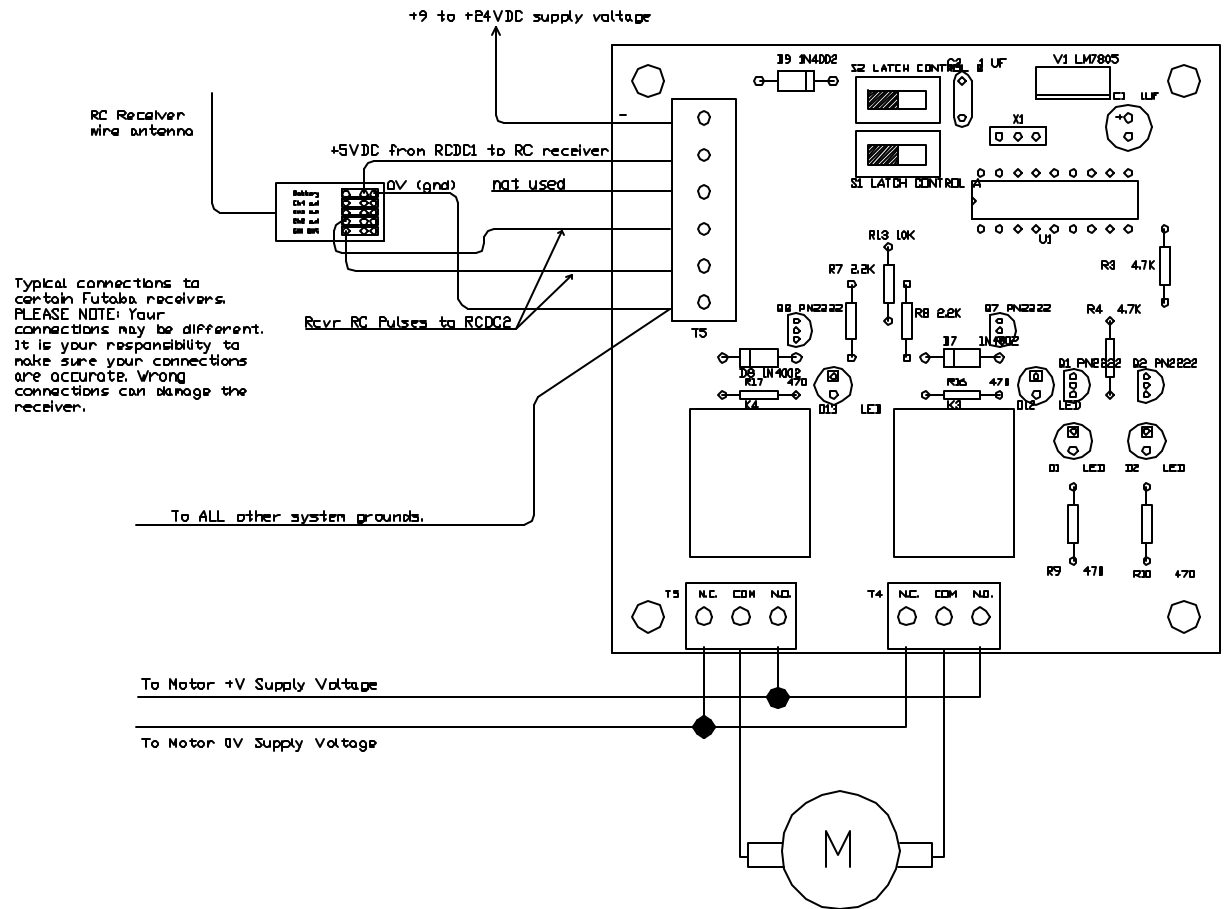

RCDC2 Connections
1 Motor in Reversing Configuration

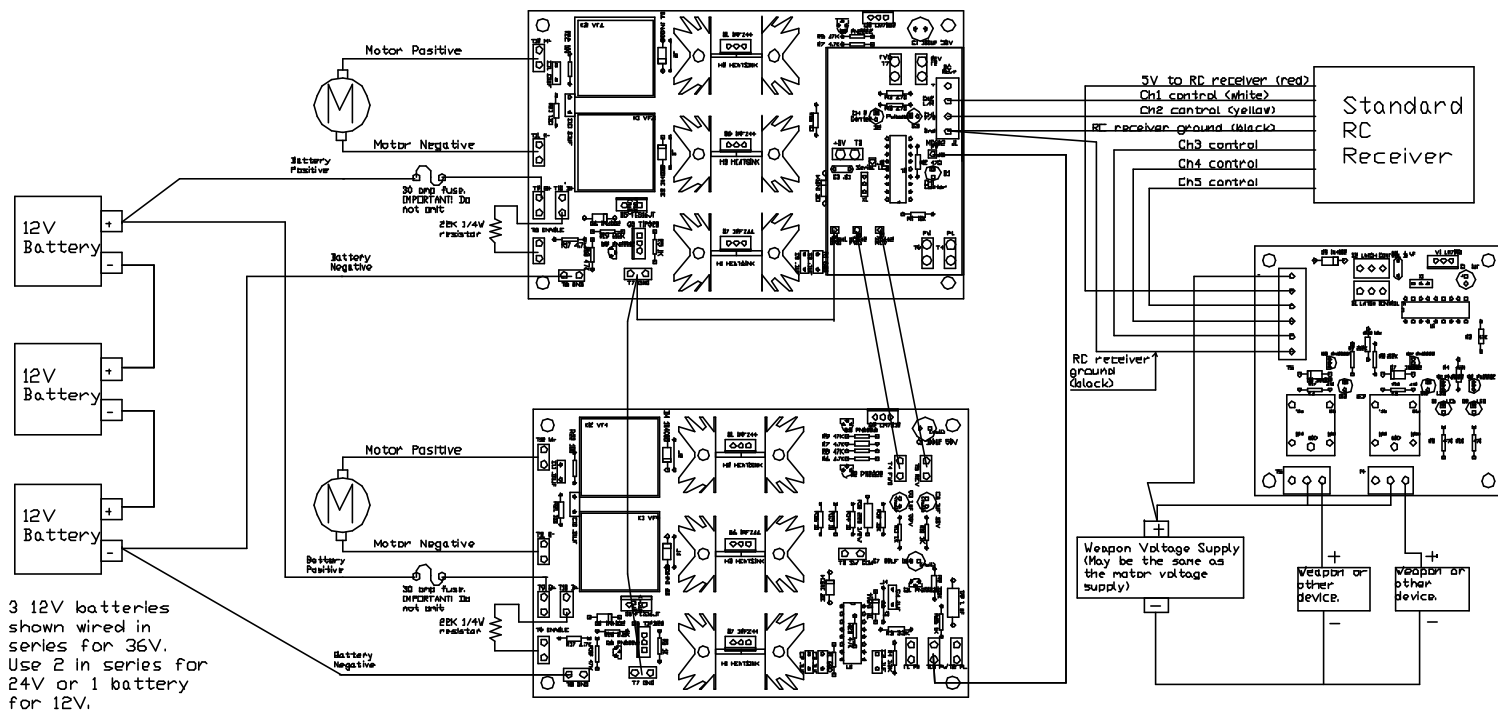

2 Motor Controllers shown using an RCIC-2 and RCDC2.