



SPECIFICATIONS – LOW COST 1206S CHARGER

Totally Automatic Switch-Mode Battery Chargers

"Suitable for Gel, Sealed & Wet Lead Acid Batteries"

Summary: **12 Volts, 3 Amp Constant Current**
(Equivalent to 6 Amp tapered charger in charging time)

- **Input 115 VAC (range 90 VAC to 132 VAC)**
 - Suitable for U.S., Canada, other 115VAC countries & Japan (100VAC).
- Automatic Cut-off and then true Float. Can be left connected indefinitely without harming the battery.
- **De-sulfation of battery. Increases battery life.**
- **UL and cUL (CSA) Listed.**
- Meets FCC Class B. High level of electro-magnetic interference filtering.
- Suitable for off-board application. Optional on-board inhibit can be provided.
- Many advance features described in this spec.
- **Very small size and very lightweight**

Explanation of the Features:

The advance technology of the OEM Battery Chargers supplied by Soneil is fundamentally different from other battery chargers. The conventional linear battery charger is an electrical device whereas the 1206S is a light weight sophisticated electronic device.

Model 1206R is available for 230VAC applications.

1. Switch-Mode Technology:

Most of the battery chargers use linear technology, which convert the 115VAC to 12 VDC at 60 Hz. This requires a large transformer, which has the disadvantage of lower efficiency resulting in higher heat generation, larger size and weight.

Soneil's Battery Charger transforms the 115 VAC into 12 VDC at about 100,000 Hz (1667 times faster than conventional charger), which requires a much smaller transformer and this results in a unit of smaller size, low weight and improved

efficiency.

The 1206S uses sophisticated electronic circuitry with microchips. All present day computers use switch-mode technology.

2. **International Safety Approvals & Listing:**

Both UL & cUL listed.

3. **Input Requirements:**

- a) 90VAC to 132VAC
- b) 47 - 63 Hz

Input AC tolerance +/- 20%. This means 1206S will operate satisfactorily in areas where the input voltage is low.

This charger is also **suitable for every part of the world** where 115 VAC is used and for **Japan** where input is 100 VAC.

4. **Output:**

3 Amps Constant Current @ 12 Volts DC
(Equivalent to 6 Amps tapered charger in charging time)

- a) Line Regulation @ Full Load 1%
- b) Load Regulation @ 4%
- c) **Ripple Voltage:** Very low 1%

The peak to peak ripple voltage into a resistive load is less than 200mV for the output voltage above 12 VDC.

5. **Charging Cycle:**

The charging curve is attached. The explanation of the charging cycle is as following.

Stages	Condition	Mode*	Current	Voltage	LED Indication
Stage 1	Charging Pulse mode	Pulse mode	3A Pulsing	0.5V to 5.0V	Flash
Stage 2	Constant Current mode	CC mode	3A	5.0V to 14.7V	Orange
Stage 3	Constant Voltage mode	CV mode	Reduces from 3A***	Holds at 14.7V	Orange
Stage 4	Standby Voltage mode	Standby CV mode	Reduces to zero	Maintains 13.6V	Green
	Recharging mode	CC mode	3A	13.6V	Orange

* CC mode = Constant current charge

* CV mode = Constant voltage charge

*** See Stage 3 description below

Stage 1: Deep Discharge Charging Pulse Mode: LED Flash

The charger starts charging at 0.5V and give pulse current up to 5V. This has effect of removing loose sulphation formed during deep discharge state of the battery.

Stage 2: Constant Current Mode (CC): LED Orange

The charger changes to constant current 3A. When the battery voltage reaches up to 14.7V, the charging stage changes from CC (Constant Current) to CV (Constant Voltage) mode.

Stage 3: Constant Voltage Mode (CV): LED Orange

The charger holds the battery at 14.7V and the current slowly reduces. When the current reaches at 0.5C (C = Battery Capacity), this point called the Switching Point. The Switching Point is one of the great feature of this battery charger that it can adjust the current automatically according to battery capacity. Other chargers are not capable to adjust the current automatically.

Stage 4: Standby Voltage Mode: LED Green

The charger maintains the battery voltage at 13.6V and current slowly reduces to zero. Charger can be left connected indefinitely without harming the battery.

Recharging: LED Orange

If the battery voltage drops down to 13.6V, the charger changes from any mode to Constant Current mode and restart charging. The charging cycle will go through Stage 2 to Stage 4.

Soneil charger can charge gel, sealed or wet lead acid batteries without use

of any switch.

6. **Two colours and function in one LED:**

LED is used to show the charging status. When the LED is Orange, the charger is in charging or recharging mode and the current is 3 A constant. When the LED Green, the charger is in Standby mode and no current (zero) is flowing.

7. **Protection:**

a) **Reverse polarity protection** - provided

b) **Short circuit protection** - provided

c) **Over-Voltage Protection** - provided

d) **Over current protection** - provided

e) **AC Surge Protection** - provided

f) **Soft start and stop:** Starts and stops gradually.
No sudden in-rush of current. This protects both the batteries and any other circuits connected to the charger.

8. **De-sulfation of battery:** The charger will remove loose sulfation and increase the battery life. (Hard sulfation cannot be reversed).

9. **Electromagnetic Interference (EMI):**

The charger will not generate excessive radiated or conducted emissions. No interference with TV, radio, computer or other equipment.

Meets FCC Class B.

10. **On-board Feature:** Optional

The optional model has a third output wire, which provides an Inhibit signal that will prohibit the operation of the vehicle's motor controller whenever the charger is plugged to an AC source.

Inhibit signal: The Inhibit signal is an open circuit output, leakage less than 5 microAmp or less, when the charger is not connected to an AC source. This signal will be less than 50 mV DC while sinking 10 mA when the charger is connected to an AC source.

11. **Size & weight: Very Small**

Length - 4.3" (110 mm)

Width - 2.4" (60 mm)

Height - 1.2" (30 mm)

Weight: 14 Oz (400 grams)

Ref: SPEC1206S.022701

CHARGING CURVE
MODEL 1206S & 1206R
SONEIL 12V/3A CHARGER

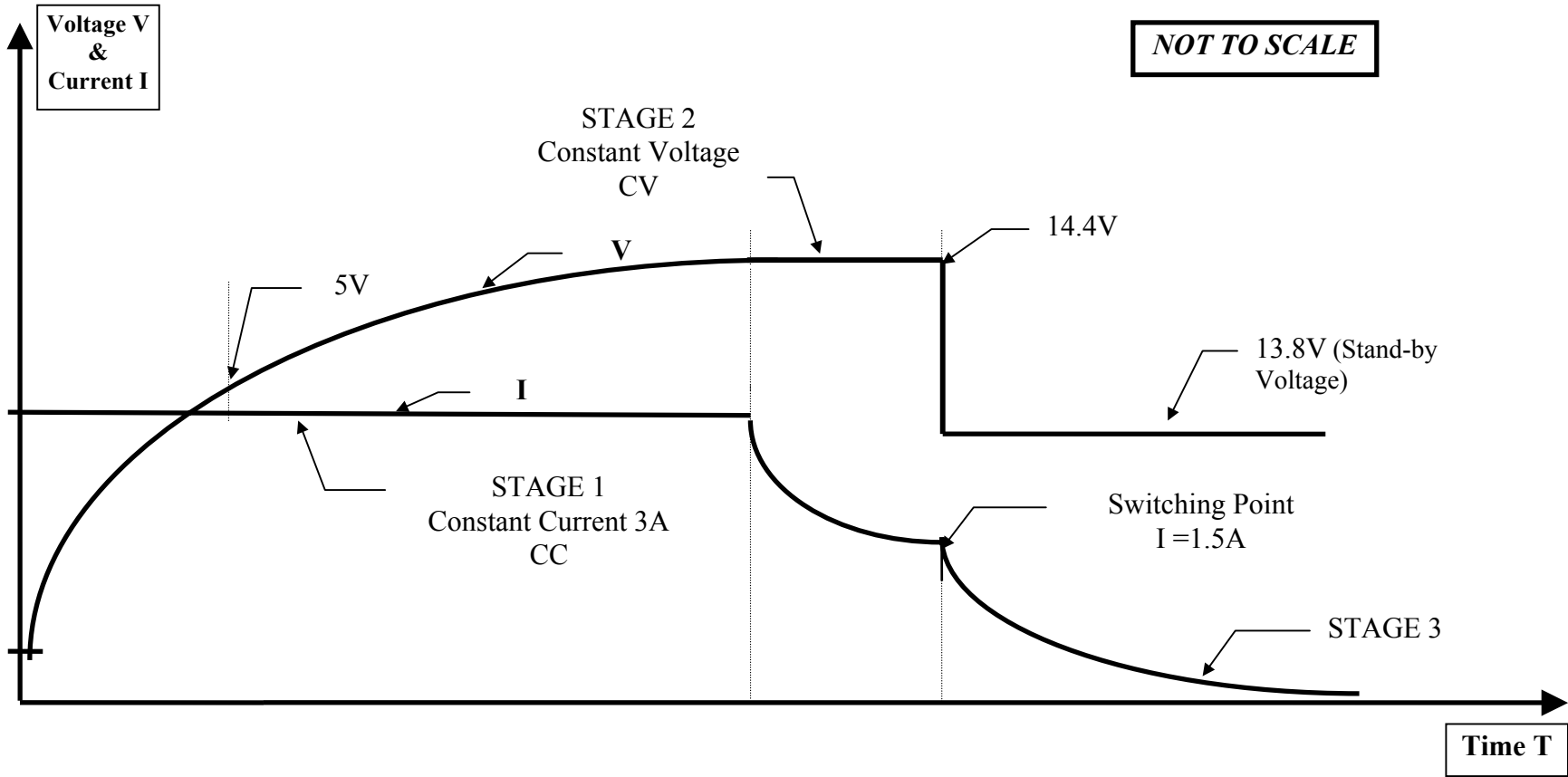

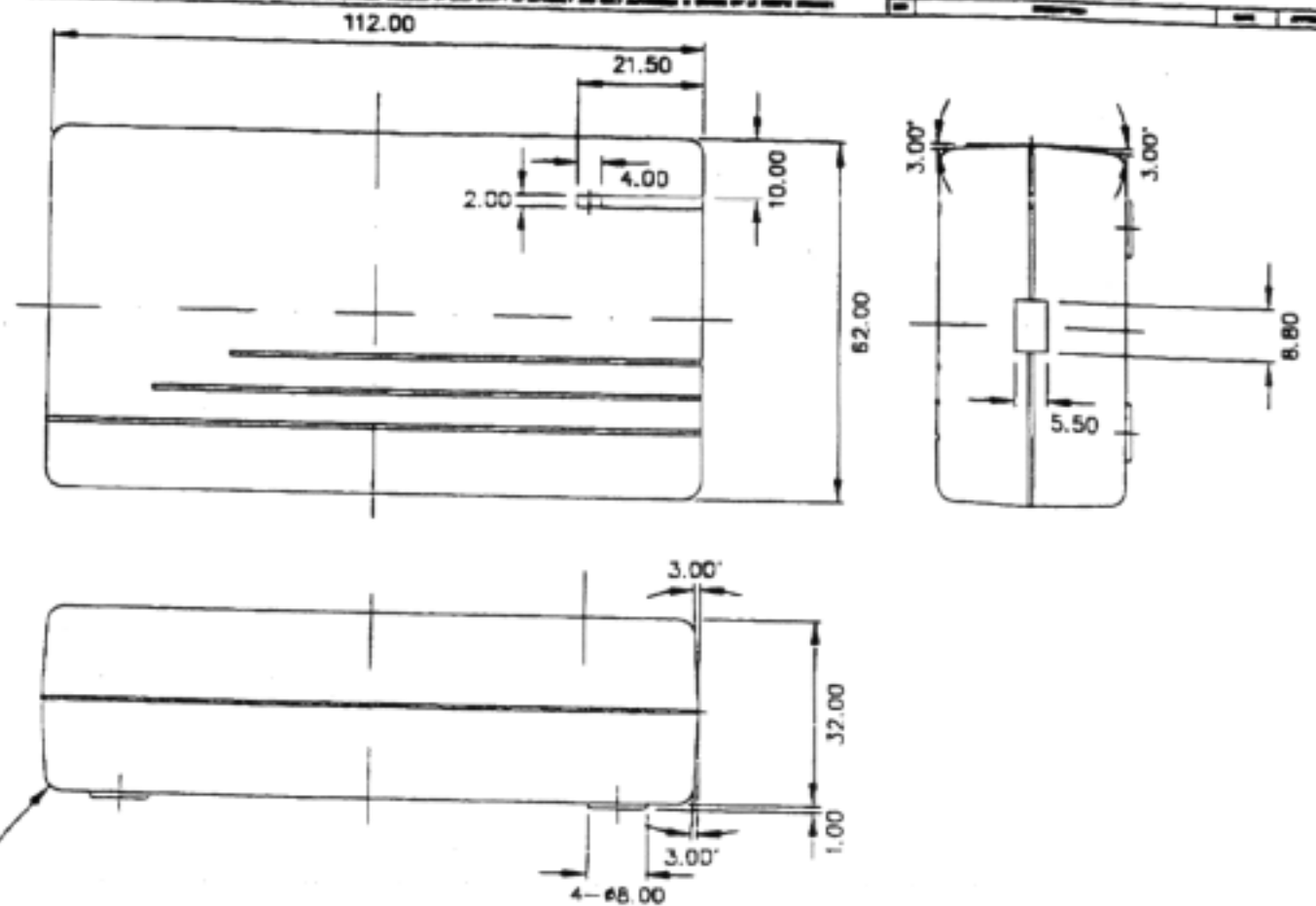

4-R3

THIRD ANGLE PROJECTION	UNLESS OTHERWISE SPECIFIED	SIGNATURES	DATE	SCALE	TITLE
	DIMENSIONS ARE IN IN. TOLERANCES ON: 1 PL. DIMENSIONS & 2 PL. DIMENSIONS & ANGLES & FRANCHISE &	DRAWN	MCL	1 : 1	CASE
		CHECKED			
		ENGINEER	(Signature)		
		DESIGNED			